

The Izze-Racing laser ride height sensor is designed to measure ride height with micron-level resolution and sub-millisecond response using contactless laser triangulation. These sensors are essential for aerodynamic research, development, and tuning, but are also used for suspension tuning, chassis stiffness analysis, tire deflection, and other contactless measurements.

The sensor is capable of measuring ride heights from 30 to 310mm with micron-level resolution, outputting data at 830Hz using CAN 2.0A protocol, enclosed in a compact IP66 rated aluminum enclosure with a Deutsch autosport connector, and priced as the most affordable motorsport-grade laser ride height sensor.



SENSOR SPECIFICATIONS

Measurement Range	30 to 310mm
Resolution (matte object)	< 0.02mm at 30mm < 0.4mm at 300mm
Accuracy (matte object, 25 °C)	±0.2mm at 30mm ±2.5mm at 300mm
Thermal Drift	±0.05mm/°C at 30mm ±0.35mm/°C at 300mm
Laser Spot Size	2.0mm x 0.8mm
Laser Class	1, IEC 60825-1:2007
Laser Wavelength	655nm
Temperature Range	-10 to 50 °C
Optimal Warm-up Time	10 minutes
Update Rate	830Hz, < 1ms response time
Valid Object Reflectance	90 to 6%
Ambient Light Immunity	> 5,000 lux

ELECTRICAL SPECIFICATIONS

Supply Voltage	8 to 32V
Power Consumption	< 900mW

MECHANICAL SPECIFICATIONS

Weight	180 g
L x W x H (max, 60° FOV)	82.3 x 44.3 x 27 mm
Protection Rating	IP66
Vibration	MIL-STD-202G, 213B, C-I
Shock	MIL-STD-202G, 201A

CAN SPECIFICATIONS

Standard	CAN 2.0A (11-bit identifier), ISO-11898
Bit Rate	1 Mbit/s
Byte Order	Big-Endian / Motorola
Data Conversion	0.01mm per bit, signed
CAN ID's (Default)	LF Sensor: 1255 (Dec) / 0x4E7 (Hex) RF Sensor: 1256 (Dec) / 0x4E8 (Hex) LR Sensor: 1257 (Dec) / 0x4E9 (Hex) RR Sensor: 1258 (Dec) / 0x4EA (Hex)
Termination	None

CAN ID: 0x4E7 (Default)

Ride Height (mm)		Raw Ride Height (bit)		Unused		Unused	
Byte 0 (MSB)	Byte 1 (LSB)	Byte 2 (MSB)	Byte 3 (LSB)	Byte 4 (MSB)	Byte 5 (LSB)	Byte 6 (MSB)	Byte 7 (LSB)

WIRING SPECIFICATIONS:

Connector	Deutsch ASL006-05PN
Mating Connector	Deutsch ASL606-05SN

Pin 1	CAN -
Pin 2	CAN +
Pin 3	POWER
Pin 4	GND
Pin 5	NC

SENSOR CONFIGURATION:

To modify the sensor's CAN ID, send the following CAN message at 1Hz for at least 10 seconds and then reset the sensor by disconnecting power for 10 seconds:

CAN ID: Current CAN ID

New CAN Base ID (11-bit)		Unused				Programming Constant	
Byte 0 (MSB)	Byte 1 (LSB)	Byte 2	Byte 3	Byte 4	Byte 5	Byte 0 (MSB)	Byte 1 (LSB)
1 = 0x001						30000 = 0x7530	
⋮							
2047 = 0x7FF							

CAN messages should only be sent to the sensor during the configuration sequence. **DO NOT continuously send CAN messages to the sensor.**

DIMENSIONS:

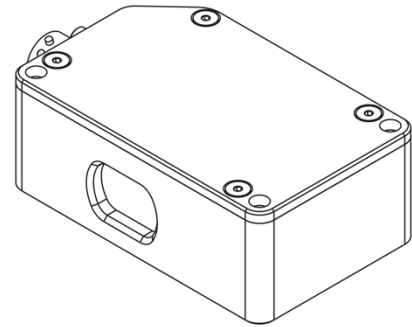
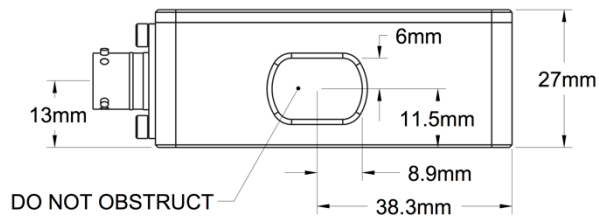
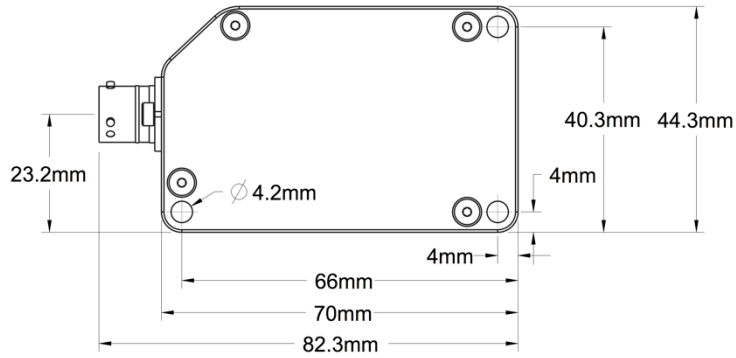

INSTALLATION INFORMATION:

- Mount the sensor **perpendicular to the direction of the motion**
- **Avoid direct sunlight**
 - o As with all laser ride height sensors, exposing the laser's beam to direct sunlight may increase signal noise and cause an intermittent loss of signal
 - o Mount the sensor under the chassis such that the laser's line of sight is shielded from sunlight exposure
- Mount the sensor **away from hot objects** and airstreams, as thermal transients will cause a thermal drift in the measured ride height
- If possible, **insulate the sensor from harsh vibrations** using rubber mounts
- **Shield the sensor** from contaminants and debris

ADDITIONAL INFORMATION:

- If there is a loss of signal, the sensor will hold the last valid measurement for up to 2 seconds and will output a minimum distance of 23mm if the signal is lost for over 2 seconds
- Accuracy and resolution is optimal at shorter distances

WARRANTY:

All sensors come with a 30-day return policy and have a 1-year warranty from manufacturing defects. If there is ever an issue, please contact us at +1 443 765 7685 / support@izzeracing.com